

HANSER

Gerd Pötsch, Walter Michaeli

Injection Molding

An Introduction

ISBN-10: 3-446-40635-2

ISBN-13: 978-3-446-40635-3

Leseprobe

Weitere Informationen oder Bestellungen unter
<http://www.hanser.de/978-3-446-40635-3>
sowie im Buchhandel

8 Special Injection Molding Techniques

The quality and technology of the means of production, the quality of the products, and the efficiency of the process chain during manufacturing can determine the growth and continued existence of production segments of companies, and in some cases even of whole industry sectors. Strong international market competition means that a company not only has to consistently develop its technology, products, and workforce, but it also has to create innovative production concepts to counter cost pressure and comply with the rising quality requirements of its customers. In such a scenario, both the ongoing expansion of existing technologies and the development of new ones are very important indeed. Against this background, special injection molding processes have gained an enormous importance since the early nineties of the last century [1–15]. In the next section the most important special injection molding processes will be presented.

8.1 Multicomponent Injection Molding

Multicomponent injection molding defines the production of injection molded parts that consist of two or more different plastics and can be distinguished by color, mechanical properties, or other factors. The process offers the possibility of manufacturing parts cost-effectively in only one step and integrating special features (optics, design, haptics), seals, or assembly during the injection molding process. Throughout the past years, multicomponent injection technique has increasingly gained importance. This is, on the one hand, created by the demand for more sophisticated products and, on the other hand, rising by the efforts of rationalization. The development of the multicomponent injection molding generated numerous process variants that took hold on the market [16, 17]. The classification of the multicomponent injection molding processes is generally made by differentiating between “overmolding” and “sandwich injection molding” [18].

8.1.1 Overmolding

A step all different overmolding processes have in common is that the materials are injected into the cavity through two or more separated gating systems. Depending on the time related to the injection of the materials, it can be distinguished between simultaneous and sequential processes (Fig. 8.1).

Regarding mold and machinery, the bi-injection technique is the simplest variant of multicomponent injection molding. The materials are injected simultaneously into the cavity through different gates in a one-step process. The joining of the melts and the arising weld (contact) line is more or less uncontrollable. The lacking reproducibility of the contact line position is unacceptable for most applications; therefore, this process is rarely employed.

Bi-injection
technique

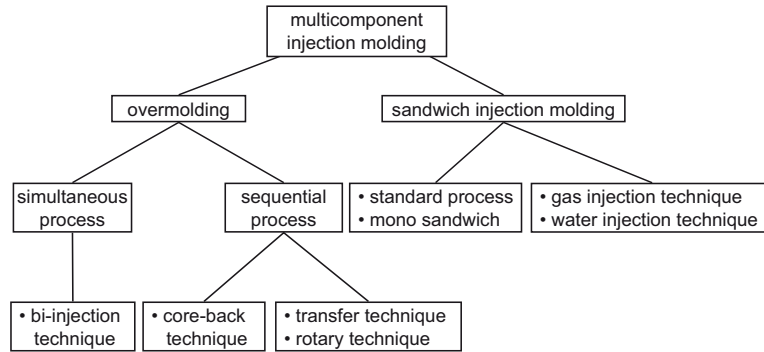

Figure 8.1: Classification of multicomponent injection molding processes

Sequential process	<p>In the sequential process, the components are injected into the different cavities or cavity areas in succession. In this process, a preform is made, which is overmolded with a second material in a second step. As an essential characteristic of the sequential processes, the molded parts show defined geometric shapes that are connected in different ways. In certain areas the parts have well defined properties, for example, different color or hardness. Such parts can be produced by manufacturing the preform on an injection molding machine and then using it as an insert for subsequent overmolding with a second injection molding machine. However, the sequential process on only one injection molding machine offers a considerable potential for rationalization of the production.</p> <p>In principle, two different mold concepts can be distinguished for the manufacture of overmolded parts: the “core-back technique” and the “transfer and rotary technique” (Fig. 8.1).</p>
Transfer technique	<p>The characteristic feature of the transfer and the rotary technique is that the preform is completely or partially demolded during a short mold opening and is then transported to another larger cavity.</p> <p>In the transfer technique, the transport is realized by a motion of translation which can be implemented by a robot system, for example.</p>
Rotary technique	<p>The rotary technique is the most frequently applied process in overmolding. Today, different variants of the rotary technique have been established. The most widespread techniques are the rotary table [19, 20], the rotating mechanism in the mold [21, 22] and the inset rotating mechanism in the mold [23] (Fig. 8.2).</p>
Functional principal of rotary technique	<p>The different variants of the rotary technique are based on the same principle, shown for the rotary table in Fig. 8.3. During each cycle, one preform and one overmolded part are simultaneously manufactured. After mold opening, the overmolded parts are demolded and the preforms are transported to the larger cavity by a rotational movement. In contrast to the transfer technique, the preforms are not demolded completely. They remain in the section of the mold which executes the rotation. After mold closing, the next injection phase starts.</p>
Horizontal rotary technique	<p>Beside the above mentioned vertical rotary technique, the so-called horizontal rotary technique has gained more importance since the year 2000. Similar to a stack mold, the mold features two parallel parting planes with cavities for the preform and the overmolded part. The preform is transported by a rotation of the middle segment around its vertical center</p>

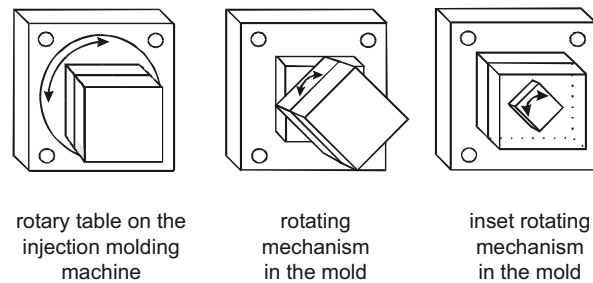

Figure 8.2: Process variants of rotary technique

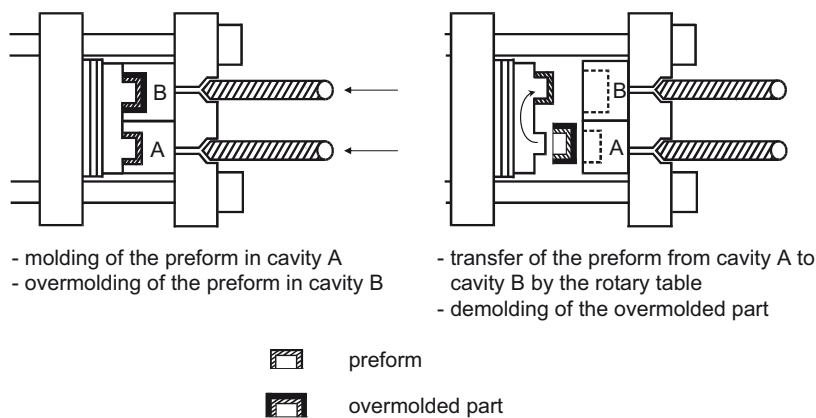

Figure 8.3: Functional principle of rotary technique (rotary table)

line. The middle segment can be designed as a plate [24, 25], a cube [26, 27] or a frame that contains pivoted single segments [28, 29]. Depending on the design of part and middle segment, they are rotated by 90° or 180°. Figure 8.4 depicts the functional principle of 90°-cube mold technology.

In contrast to the transfer and the rotary techniques, in the core-back technique the mold remains closed during the complete cycle (Fig. 8.5). After injecting the first material, a shut-off slide moves back and opens the cavity for the second component [30]. However, this technique can only be applied if the cavity for the second component can be opened and closed by axial movements of insets or slides. In addition, the complexity of the parts is limited because the preforms are not demolded but released only partially. Moreover, the sequential production of preform and overmolded parts leads to comparatively long cycle times.

Nearly all applications of overmolding should aim at an adhesive connection between the materials because this connection is easier to realize than a positive joint. The adhesion between the processed materials is a general requirement of an adhesive connection [31, 32].

Determining the bond strength represents the main problem when designing overmolded parts. Currently, it is impossible to predict the bond strength of polymer combinations produced by overmolding. Limited knowledge regarding adhesion and diffusion mechanisms,

Core-back
technique

Adhesion

Bond strength

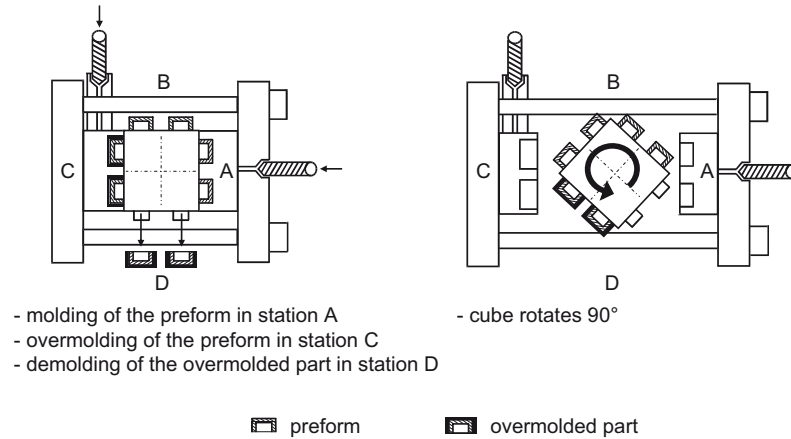

Figure 8.4: Functional principle of 90°-cube mold technology

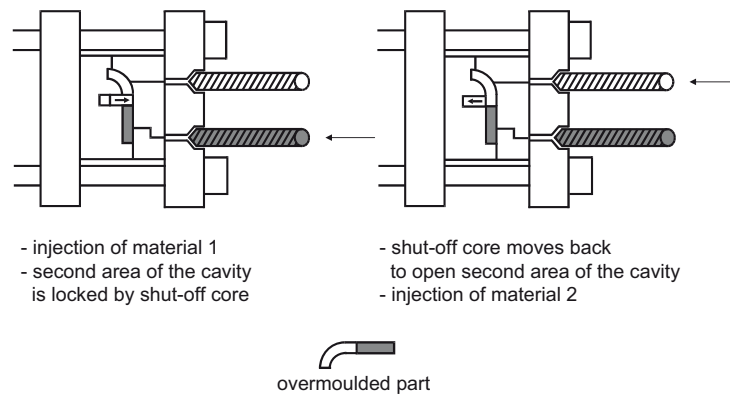

Figure 8.5: Core-back technique

as well as the influence of process parameters, part geometry, and mold layout on the bond strength [33, 34], make predictions difficult.

Test methods for bond strength
 Assembly injection molding

Bond strength for the various material combinations can be approximated by performing two component tensile tests or peel tests on specifically manufactured specimens (Fig. 8.6).

Assembly injection molding is defined as the processing of incompatible materials that produce no adhesive bonding [35, 36]. Here, the transfer of tensile and shear force between the materials is realized by undercuts, openings, or other elements that create positive joints. These elements provide a mechanical connection.

The injection molding machines used for overmolding require several plasticizing units that can inject parallelly and in a programmable order. The arrangement of the units has to match the mold. Therefore, the arrangement is flexible (axial, vertical, lateral, diagonal). Applications with up to six components or even plasticizing units are known.

Examples for parts produced by overmolding include:

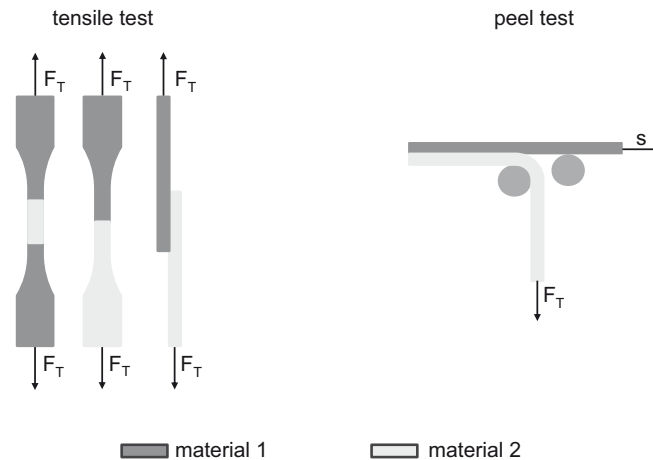

Figure 8.6: Test methods to determine the bond strength

- Automotive tail lights (PS or PMMA, three to four colors, machines with clamping forces up to 10.000 kN) Applications
- Toothbrushes (PP and TPE, up to five plasticizing units)
- Keyboards for pocket calculators, typewriters, etc., with abrasion resistant labels (up to five colors)
- Toys

8.1.2 Sandwich Injection Molding

Sandwich injection molding refers to the production of a sandwich structure via injection molding. Different polymer melts are injected into the cavity through the same gate in succession. Because of the fountain flow of polymer melts, a characteristic sandwich structure with a skin and a core layer is formed [37, 38, 39].

The process cycle of sandwich injection molding is shown in Fig. 8.7. In the first step, the skin component is injected. In the second step, the core material is injected into the still fluid centre of the skin material. In most cases, additional skin material is again injected before the injection phase ends, so the core material is completely enclosed by the same material and at the same time rinsed out of the injection nozzle. In order to reach a perfect quality of the surface without defects and differences in gloss, strong variations in melt front velocity and cavity pressure have to be avoided. Thus, the sequential injection phases should have a short overlapping time with a short simultaneous injection of skin and core material to prevent the flow front from stopping.

Depending on the number of injection cylinders, standard sandwich injection molding and mono sandwich injection molding can be distinguished. Gas- and water-injection techniques present special cases of sandwich injection molding. By using gas or water as the core component, hollow sections can be produced within the part. More details about gas- and water-injection techniques can be found in Section 8.2.

Course of the process

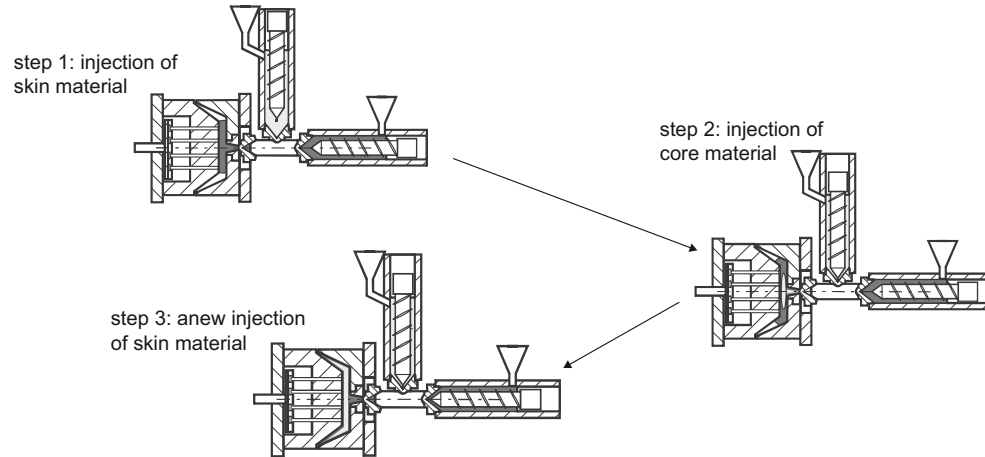

Figure 8.7: Process cycle of sandwich injection molding

Sandwich unit	The machines for standard sandwich injection molding have two plasticizing units. The sequential injection of two melts into the cavity is realized by a common nozzle head [40, 41], a mold plate [42], or coaxial hot runner valve nozzle [43]. The machines differ functionally only regarding the design of the sandwich unit.
Mono sandwich injection molding	For mono sandwich injection molding, two melts are injected into the cavity through one injection unit. Within this injection unit, the two melts are injected one after another. The skin material is plasticized by an ancillary extruder.
Material compatibility	By combining skin and core material with specific properties, sandwich injection molding offers the possibility to produce parts with special features. However, three important criteria have to be considered when plastics materials are combined via sandwich molding [38]: <ul style="list-style-type: none"> • processing compatibility, • property compatibility, and • adhesion compatibility.

Processing Compatibility

Two materials can only be processed successfully by sandwich injection molding if their processing properties match. The viscosity ratio $k_\eta = \eta_{\text{core material}} / \eta_{\text{skin material}}$ should be $k_\eta \geq 1$ and the processing temperature range of the materials should overlap, because the two melts flow in a rather large machine or mold area through the same gating system. Besides the processing temperatures, the mold temperature range of skin and core material should be similar.

Property Compatibility

If the physical properties of the sandwich components vary too widely, high internal stresses within the part caused by cooling or loading may occur. This results in warpage or crack formation, respectively. Therefore, the elastic modulus, the coefficient of thermal expansion, and the shrinkage characteristics of skin and core material should be similar.

Adhesion Compatibility

Analogous to overmolding, the processed materials must provide sufficient adhesion to each other, otherwise delamination between the skin and core layers can occur.

In sandwich injection molding, the planar core distribution of the core material within the skin material and the boundary layer profile are the most important quality criteria. It is not possible to achieve a completely regular distribution of the materials.

In flow direction, the cross-sectional shape of the boundary layer profile is always a parabola. The shape of the parabola depends on the rheological properties of the processed polymers. Figure 8.8 shows the dependence of the boundary layer on the viscosity ratio k_η . In the case of $k_\eta < 1$, the flow front of the core material shows an obtuse, and in the case of $k_\eta > 1$, a tapered contour [38, 39].

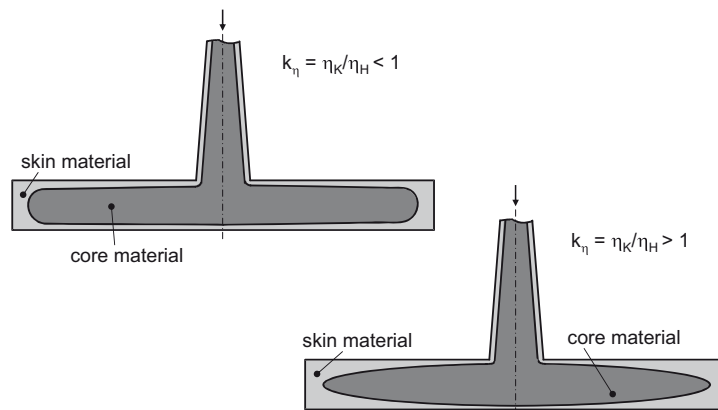

Figure 8.8: Boundary layer profile in dependence of the viscosity ratio

A good planar distribution of the core material can be obtained by adequate and skillful choice of material, geometry, and processing parameters. To achieve a regular distribution of the core component in the part, the viscosity of the skin material has to be lower than the one of the core material. For $k_\eta < 1$, the smallest variations of flow resistance lead to local advance effects (“finger effect”). Stable and reproducible flow conditions are only possible for $k_\eta \geq 1$ (Fig. 8.9) [38, 39].

Rotationally symmetrical parts show a good and regular planar material distribution. Problems can occur with non-symmetrical parts with openings or varying wall thicknesses. Such parts often have an uneven distribution of the core component (Fig 8.10) [41].

The molder has limited possibilities to influence the boundary layer profile and the planar distribution of the core component through process parameters, especially if the geometry of the part does not lend itself to sandwich injection molding. The specific use of intelligent mold technology bears the opportunity to influence the material distribution effectively and to extend the design freedom of sandwich injection molded parts. Integrating overspill cavities behind openings or part corners for example, the boundary layer profile, as well as the planar distribution of the core material can be positively influenced by an extension of the running time of the core material.

Core material
distribution

Boundary layer
profile

Planar core
material
distribution

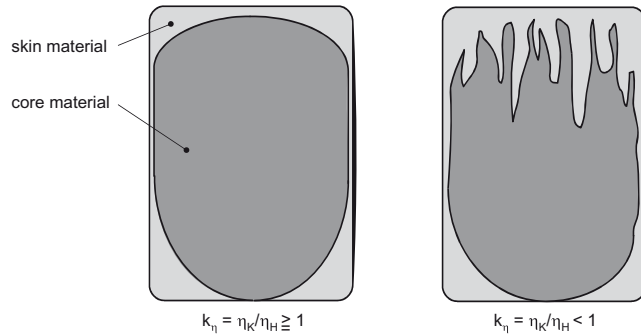

Figure 8.9: Planar distribution of core material in dependence of the viscosity ratio

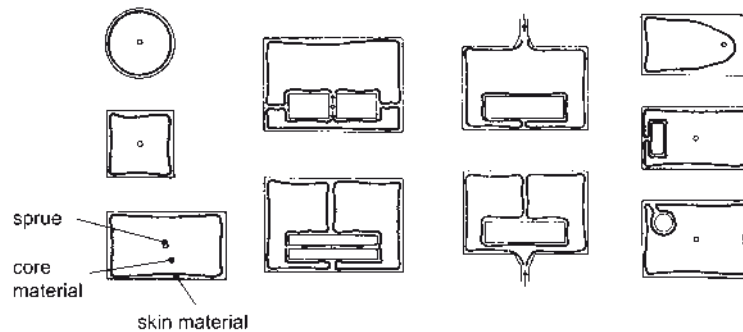

Figure 8.10: Planar material distribution in dependence of part geometry and type of gate

Applications For applications, skin and core component materials can be combined to integrate most diverse functions in one sandwich part. For example, when using fiber-reinforced materials for the core component, the inner layer provides good mechanical properties within an unreinforced, smooth outer layer. If materials filled with metal fibers or carbon black are processed as the core component, a shielding effect of the part can be realized. The application of recycled material for the core component is also possible so that less virgin material is consumed. The same holds true if a blowing agent is added to the core component, producing a foamed core and reducing the weight of the part while maintaining the surface quality. Some examples for applications produced via sandwich injection molding are:

- Housings of televisions (skin component: PS; core component: PS foamed or recycled)
- Housings of computers (skin component: ABS; core component: ABS filled with metal fibres)
- Boxes or packaging for food (skin component: PP; core component: EVOH (good barrier properties))
- Preforms of beverage bottles (skin component: PET; core component: PA (good barrier properties))
- Interior parts for automobiles (skin component: TPU; core component: ABS)
- Garden furniture (skin component: PP mineral filled; core component: SAN foamed)

8.2 Fluid Injection Technique

The fluid injection technique (FIT) is a special injection molding process for the production of hollow polymer parts. The FIT process is similar to the sandwich injection molding technology. However, instead of injecting a second polymer material as a core component, a process medium is applied. With the gas injection technique (GIT), which is also known as gas-assisted injection molding (GAIM), an inert gas, typically nitrogen, is employed. Whereas in the water injection technique (WIT), the melt is displaced by water. Both processes start with a melt being injected into the cavity. Subsequently, a fluid is injected into the melt so that the molten core of the developing part is displaced and a hollow section is formed. The fluid injection technique offers considerable potential to produce high-quality, lightweight plastic parts in short cycle times. Thus, significant advantages can be achieved compared to products that are traditionally manufactured using conventional injection molding [44–50]:

- Cutting production costs
 - reduction of cooling time and therefore cycle times
 - savings in material and weight
 - integration of process steps
 - reduction of clamping forces
- Increasing quality
 - reduction of sink marks, more even shrinkage and reduced warpage
 - enhancement of weight-specific mechanical properties
- Simplification of part and mold design by increase in design options

Obviously, not all advantages can be obtained at the same time for one specific part and certain efforts need to be made to ensure stable FIT processing. Drawbacks of the fluid injection technique typically are [44, 45, 49]:

- Additional costs (investment, operation, and maintenance costs for FIT equipment, licenses, etc.),
- Increased complexity of the processes and systems, as well as
- Increased demands on operational personnel (specialized knowledge of FIT).

Figure 8.11 illustrates the four most common process variants for fluid injection, which can be distinguished by their respective process control.

The short-shot process, in general, constitutes the simplest process variant for fluid injection. Here, an undervolumetric melt-filling of the cavity between 50 % and 95 % is characteristic. After a preferably short delay time, the cavity is completely filled volumetrically by means of the fluid. The fluid is accurately injected into the still-molten core of the pre-molding, displacing the melt successively to the end of the flow path. The advantage of the short-shot process is the comparatively simple mold and processing technology and the fact that only the amount of melt required for the actual hollow body is processed. Drawbacks to be considered are hesitation marks and problems with filling of compact sections.

In the full-shot process, as the first step, the cavity is completely filled with melt. This leads to a reproducible molding of the cavity surface without hesitation marks, variations in gloss

Course of the process

Advantages of FIT

Disadvantages of FIT

Process variants

Short-shot process

Full-shot process

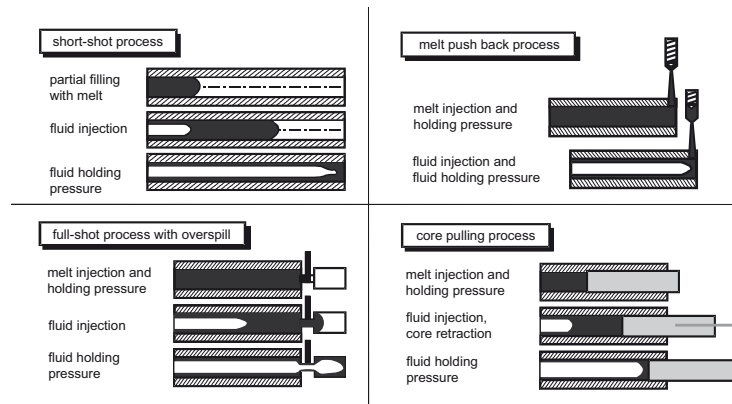

Figure 8.11: Process variants for fluid injection

levels, or sink marks. Similar to conventional injection molding, melt back pressure is then applied over the gating system during the fluid delay time in order to mold compact, thin-walled sections. Depending on injector positioning and the adjacent melt displacement, we differentiate between two different processes: full-shot process with overspill and melt push-back process.

Full-shot process with overspill	For the full-shot process with overspill, the molten core is expelled into one or more separate cavities, so-called <i>overspill</i> or <i>overflow</i> cavities. In order to apply melt back-pressure, these cavities are closed by means of a slide or valve gate. Depending on the residual wall thicknesses, the volume of the overspill cavity amounts to approximately 30 to 50% of the hollowed-out section. Ideally, the overflow material is re-granulated and processed again. However, increased material waste or additional efforts for reprocessing must be taken into account. This drawback can be eliminated by the melt push-back method.
Melt push-back process	The melt push-back method is closely related to the overspill cavity method. The fluid is injected at the end of the flow path, and the excess melt flows back into the plasticizing unit. This process creates less material waste, but it involves more sophisticated process control. The stroke of the screw being pushed back by the polymer must be set to both accept the volume of the displaced plastic and avoid fluid reaching the plasticizing unit. Sprues and runners must be sufficiently dimensioned to ensure the flowback of the polymer. When using too small diameters, sprues and runners may freeze too early.
Core-pulling process	A fourth process is the core-pulling process. The melt is injected into a cavity of variable volume. Such a cavity incorporates one or more cores that can be retracted from the cavity. After closing the mold, the cores are moved into forward position to reduce the initial cavity volume. Subsequently, the cavity is completely filled with polymer and after a set delay time with optional melt back pressure, the cores are pulled back to increase the cavity volume. In order to keep the polymer in contact with the cavity walls, the fluid needs to be injected simultaneously. However, the area where the core movement occurs is more or less visible on the molding.
Water injection technique (WIT)	During the last two decades, GIT has been well established as a special injection molding process for thermoplastics and has become a state-of-the-art technique [46–48]. But GIT has its limitations; for instance, the marginal heat transfers toward the internal gas, the eventual

foaming of the inner melt layer, and the limitation on part diameters. To overcome these disadvantages, Brunswick developed the water injection technique (WIT) at the Institute of Plastics Processing (IKV) in Aachen, Germany, in 1998 [51, 52]. Depending on part geometry and the polymer, WIT offers significant advantages compared to GIT for certain applications [49, 52–56]:

- reduction of cycle times of up to 70 %,
- slightly lower residual wall thicknesses, and
- better concentricity of the hollow sections in redirections.

Advantages of WIT

GIT and WIT are closely related processes. Nevertheless, the techniques bear considerable differences. Their applications are only partially overlapping, so that WIT is a supplement to, rather than a substitute for, GIT. Regarding the geometry for fluid injection, three different classes of molded parts can generally be manufactured:

Applications of
GIT and WIT

- thick-walled and rod-shaped parts (GIT and WIT),
- compact parts with integrated thick-walled sections (GIT und WIT), and
- flat, thin-walled parts with suitably shaped stiffening ribs (only GIT).

For these classes, different applications are shown in Fig. 8.12.

In contrast to GIT, WIT is not applied solely for compensation of shrinkage in thin-walled, flat parts (e.g., ribbed housings). WIT is predominantly used for the production of large or large-volume parts, because there is a significant reduction of cooling times compared to GIT. When using GIT, part size is limited to diameters of approximately 30 mm [51, 53, 55]. This can be attributed to extensive wall thicknesses and a pouring down of non-solidified melt inside the hollow molding during the gas holding time. Because of the strong cooling effect of water, this problem can be avoided with WIT even for large diameters.

Diameter of
GIT/WIT parts

The resulting wall thickness for GIT, as well as for WIT, is predominantly determined by the rheological and thermal melt properties [57, 58]. Process parameters, such as delay time, fluid pressure, volume flow rate, or processing temperatures have only a limited effect on the residual wall thickness. With the water injection technique, it is generally possible to achieve

Residual wall
thickness

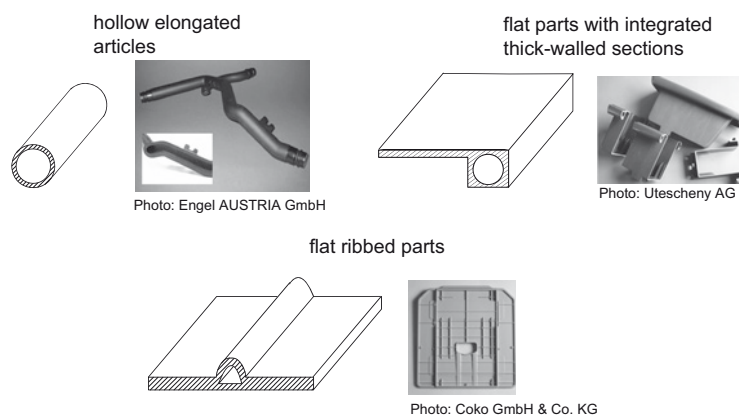

Figure 8.12: Product groups for FIT